

TECHNICAL INFORMATION & FEATURES

Preparation Sinks

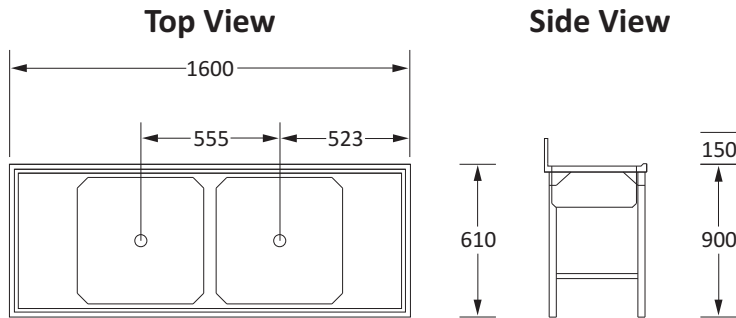

Pot Sinks

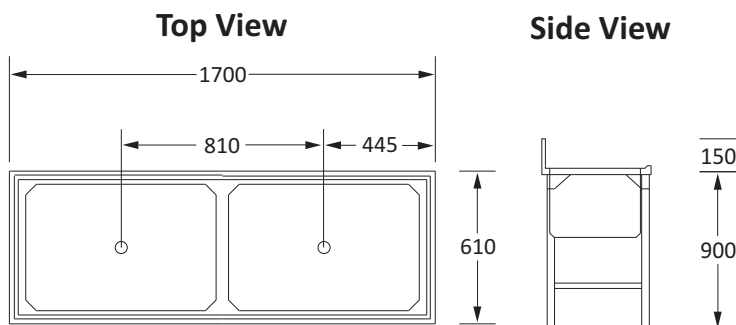
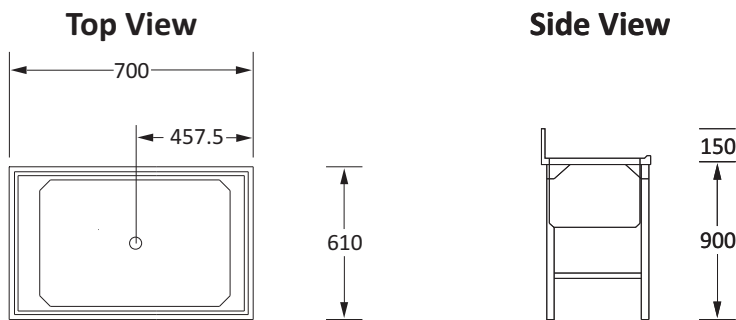

Combination Sinks

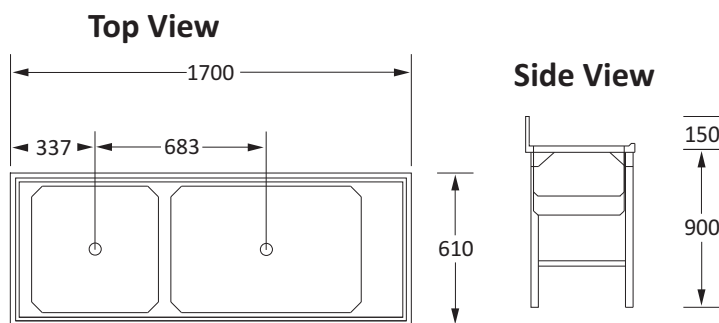

- The top manufactured from 0.9 mm 430 stainless steel
- The top has a 35 mm boxed edge with a 50 mm turndown and a return of 10 mm
- The rear shall have a 150 mm vertical splash back with a 20 mm return and a 10 mm turn down
- Angle iron frame work - Epoxy coated
- 42 x 2 mm Mild steel legs
- Corner gussets are fitted with 48 mm tubing and M10 bolts to accommodate removable legs
- 1 x 30 mm Mild steel flat bars are welded to legs at 250 mm to accommodate shelf
- Prep bowl size 500 x 500 x 250 mm
- Pot bowl size 615 x 500 x 385 mm
- Prep sink double: A = 1600 mm, Pack size 1600 x 610 x 450 mm, Weight 32 Kg
- Pot sink single: A = 770 mm, Pack size 770 x 610 x 600 mm, Weight 26 Kg
- Pot sink double: A = 1700 mm, Pack size 1700 x 610 x 600 mm, Weight 38 Kg
- Combination sink left or right: A = 1600 mm Pack size = 1600 x 610 x 900 mm, Weight 36 Kg